

# Mobil ve Telsiz Ağlar için IPv6

Alper Yeğın, IPv6 Forum

IPv6 Konferansı

Ocak 2011, Ankara

# IPv6 ile Tanışıklığım

- 1997 – 2001
  - Solaris 8 IPv6 Project – İlk IETF IPv6 standard uyumlu işletim sistemi
  - IETF (IPng, Mobile IP WGs)
  - Connectathon Interoperability
  - Solaris 8 IPv6 Code Camp
  - IPv6 Forum (Technical Directorate Member)
- 2001-...
  - IPv6 Forum
  - 4G/All IP
  - WiMAX
  - Hotspot 2.0, Smart Grids (Zigbee Alliance)

# Artan IP Adres Talebi

- Telsiz cihaz ve mobil uygulamalar baş rolde!
- Cihazlarda artış
  - Dizüstü (WiFi)
  - Akıllı telefonlar (2.5G+)
  - Tablet (3G+)
  - ...Consumer electronics, smart grids, araç takip (Zigbee, 4G, vs.)
- Bağlantı sürekliliği
  - Push mail, VoIP, IM

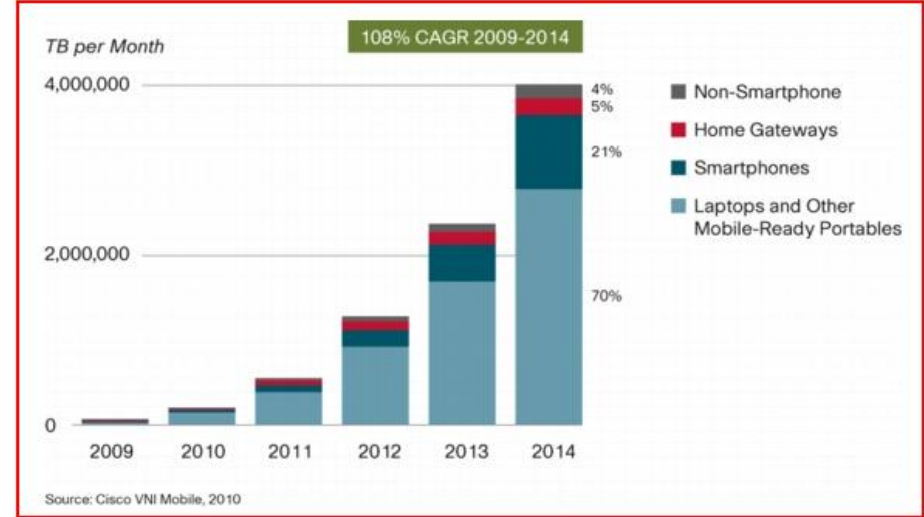

# Genişleme

- Adres genişlemesi
  - IPv4: 32 bit *157.166.226.55 (global) ve 10.1.1.1(lokal)*
  - IPv6: 128 bit *2a02:2a58:0000:0010:0202:b3ff:fe1e:8329*
- Tekrar tasarım ve yeni özellikler
  - Eski deneyimlerin birikimi
    - IP checksum gereksiz, fragmantasyon sadece kaynakta,  
...

# Network Address Translator - NAT

- NAT stres altında
  - Çok cihaz, çoklu uygulama, çoklu bağlantı
    - NAT kapasitesi: Carrier-grade NAT (CGN)
    - IP adres kapasitesi: Çoklu (zincirleme) NAT – NAT444
- NAT kaynak canavarı
  - Uygulamalar sürekli erişilebilir olmak istiyor
    - Push mail, VoIP, IM
  - NAT tablolarını taze tutmak için 30 saniyede bir bağlantı güncellemesi gerekir
  - Telsiz cihazlar “idle mode”a giremez.
  - Cihazlarda pil, ağ alt yapısında (baz istasyonu, ağ geçidi) kaynak israfı.

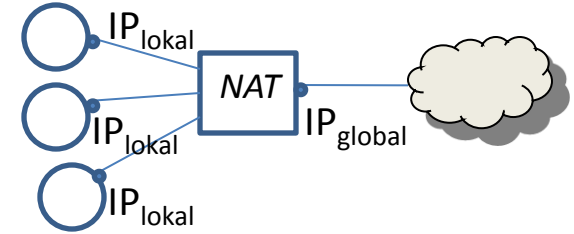

Product	TCP timeout	UDP timeout
Check Point NG FP2 firewall	60 min	40 s
Cisco IOS router NAT	1440 min	300 s
Cisco PIX firewall	60 min	120 s
Juniper Netscreen firewall	30 min	60 s
Nokia IP VPN gateway	60 min	120 s
ZyXEL Prestige 660 ADSL router	60 min	60 s
ZyXEL ZyWALL 70 firewall	150 min	180 s

Table 1. Default connection state timeouts (source: product manuals)

# IPv6 ile...

- NAT bağımlılığına son.
- Güvenlik
  - IP katmanında uçtan uca güvenlik – IPsec
  - CGA (Cryptographically-Generated Addresses) (RFC 3972)
- Tak-çalıştır
  - Stateless address autoconfiguration (RFC 2462)
    - DHCP sunucusu gerektirmeden
    - Sensor cihazlar için ideal
- Fonksiyonel genişleme olanakları
  - Extension headers, options
    - Hop-by-hop, destination, routing, fragment, security, ...

# Mobile IP

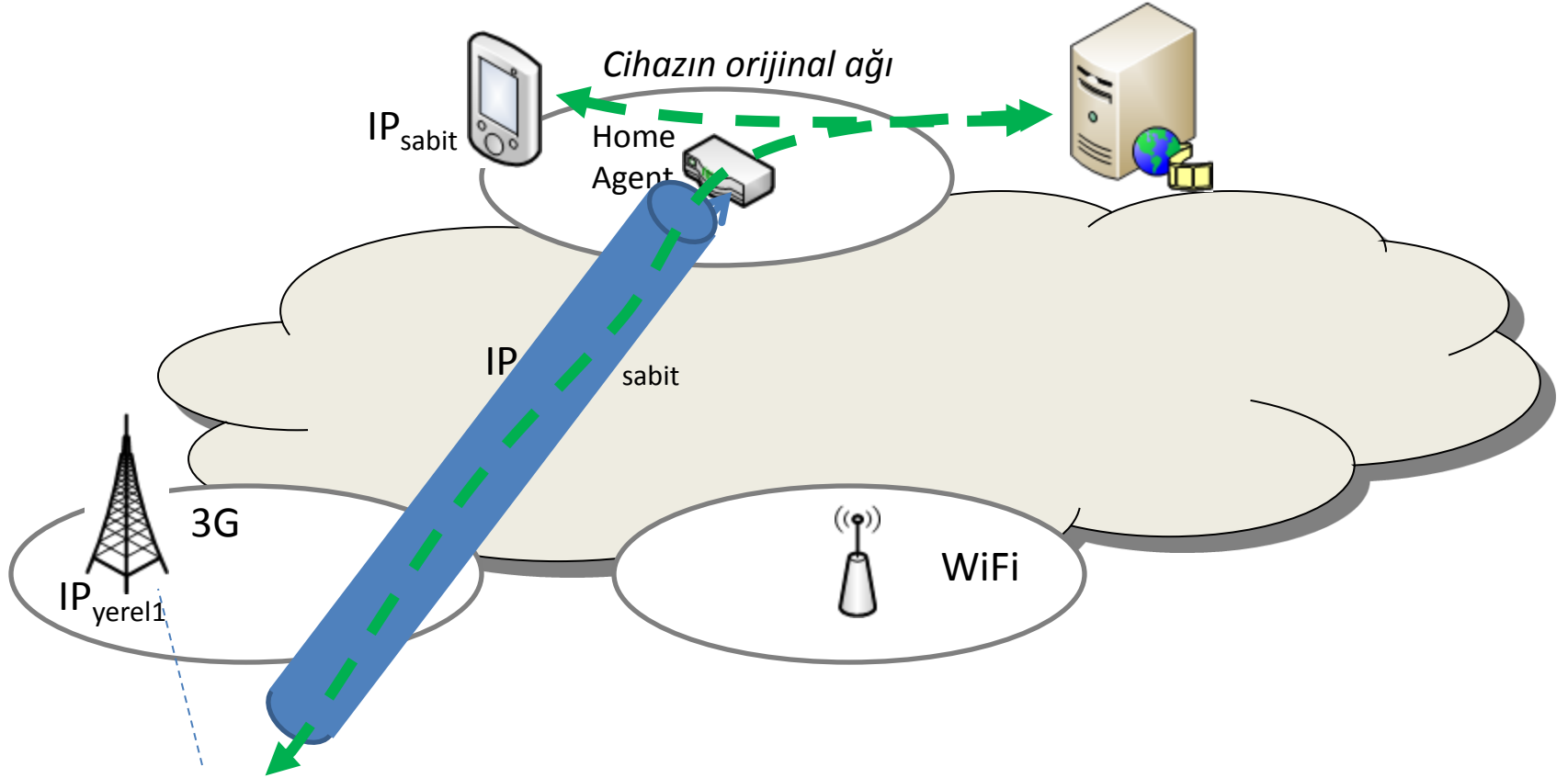

# Mobile IPv4

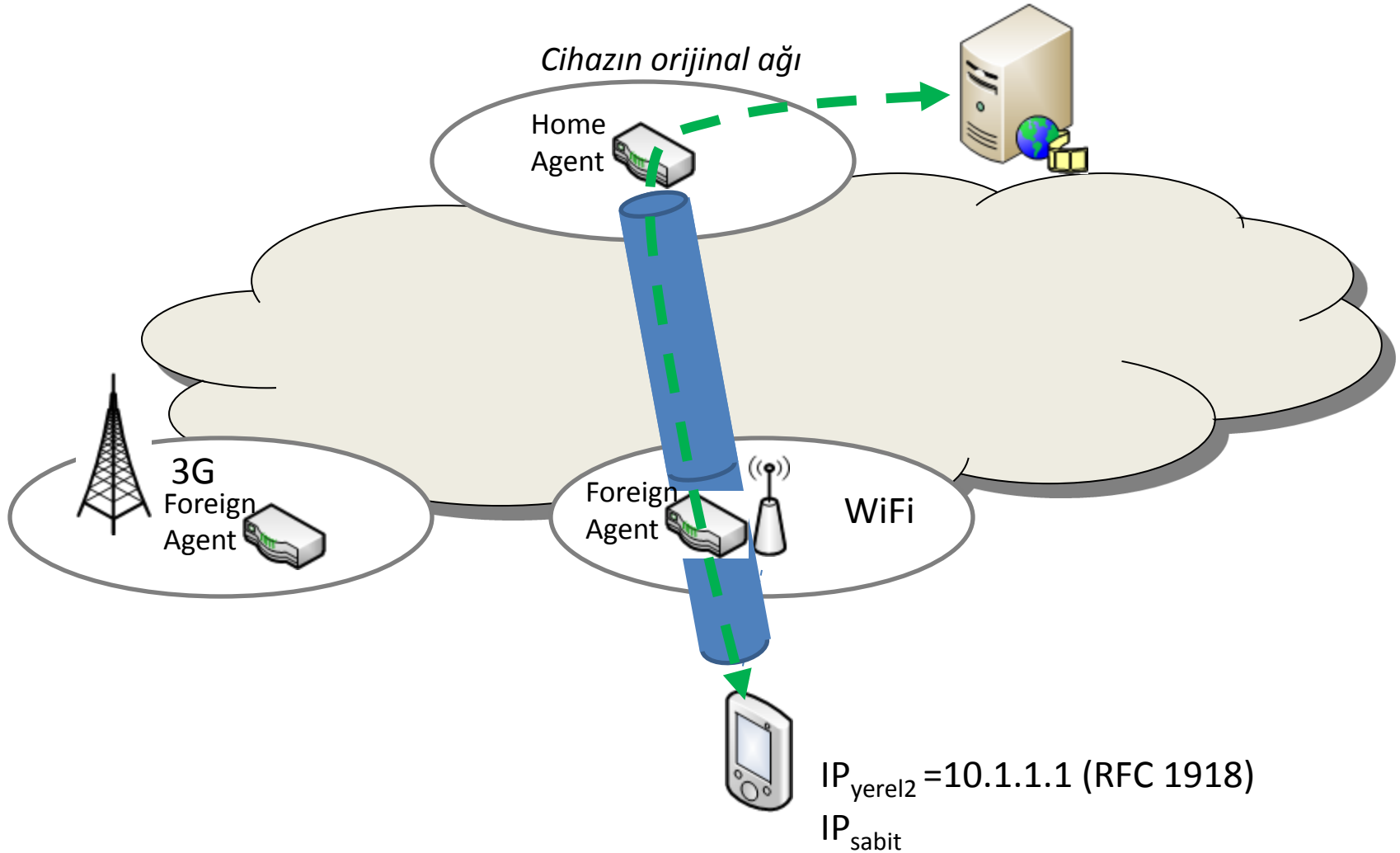

# Mobile IPv4

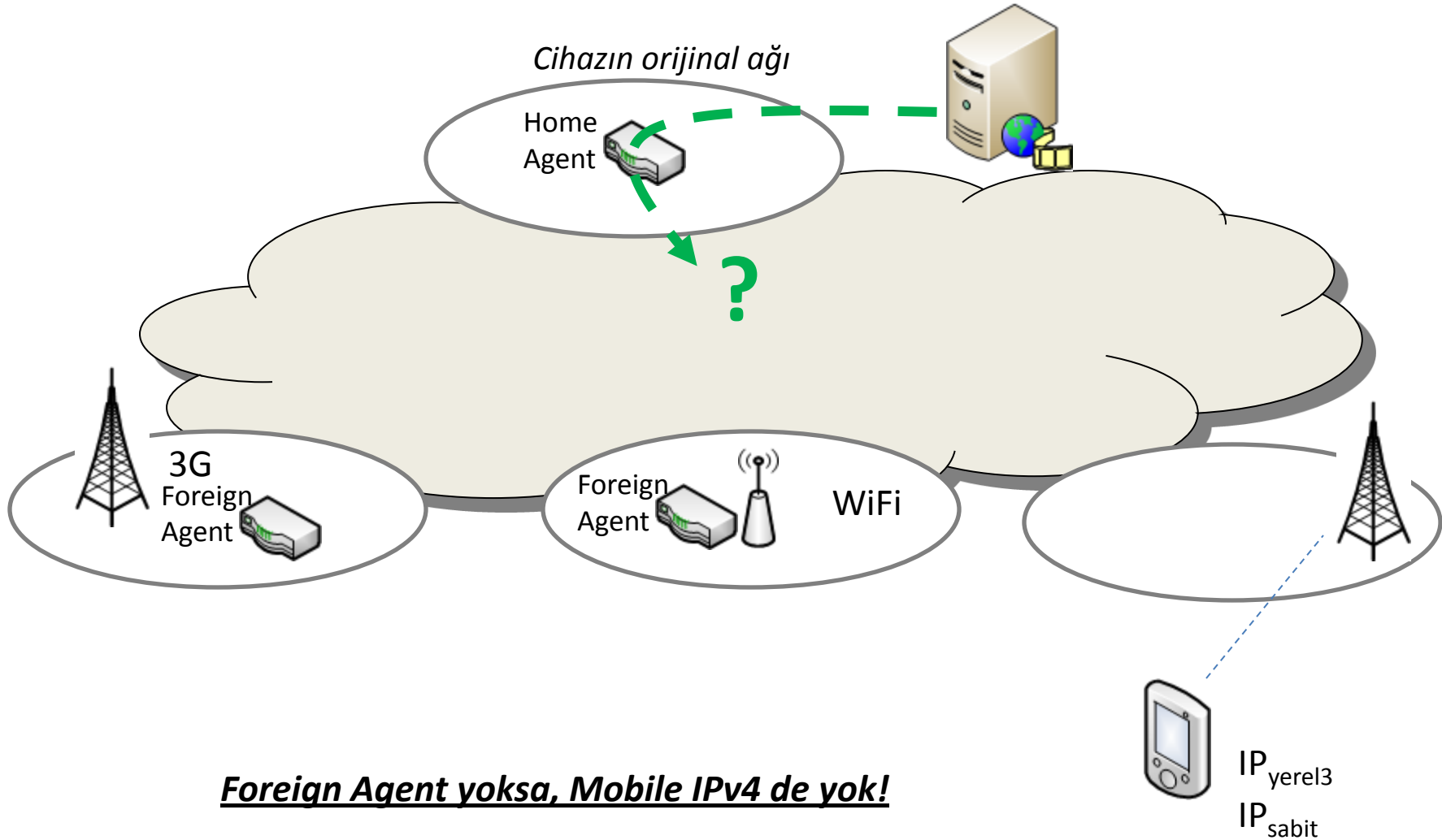

# Mobile IPv6

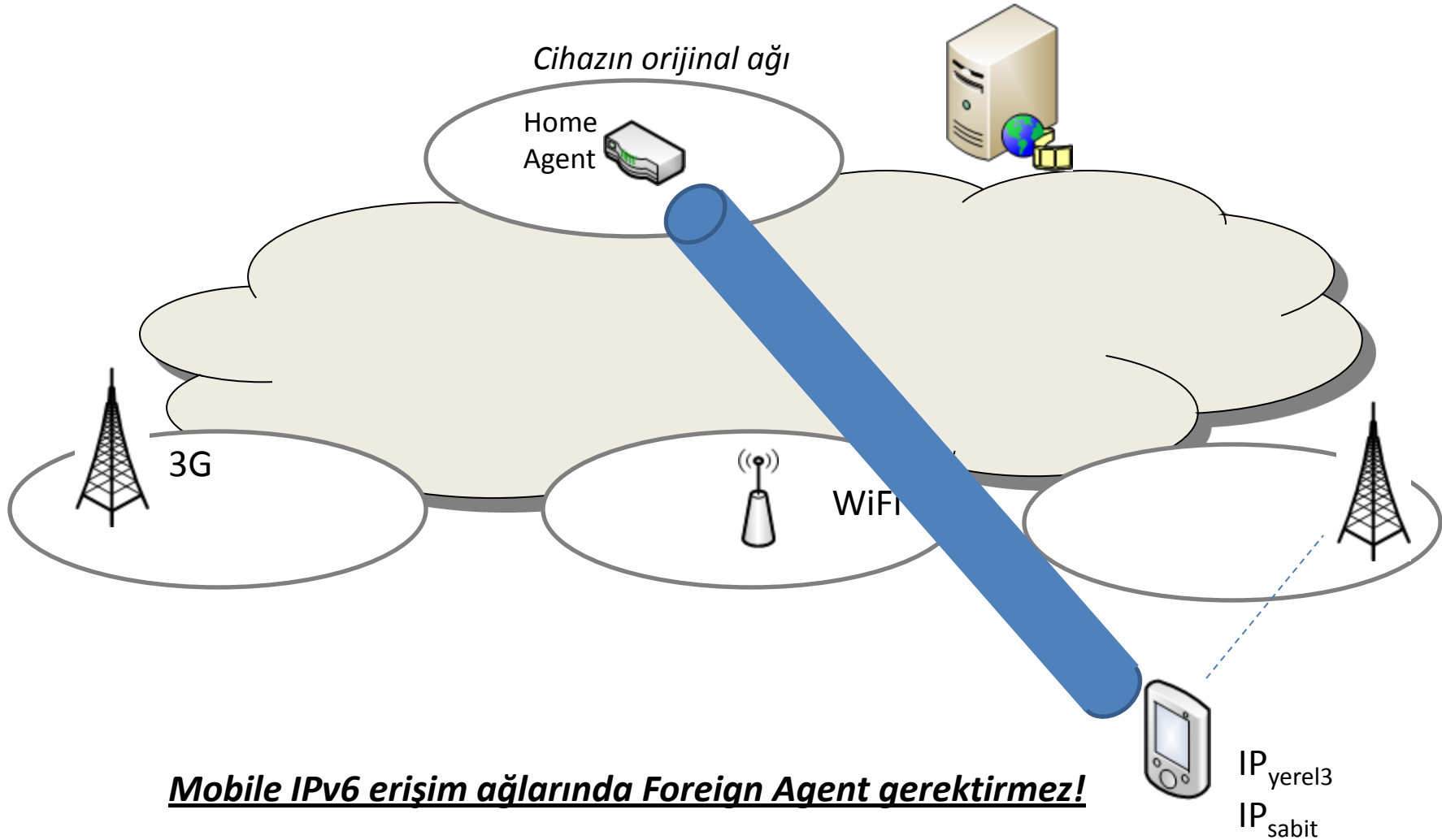

# Dual-Stack Mobile IPv6

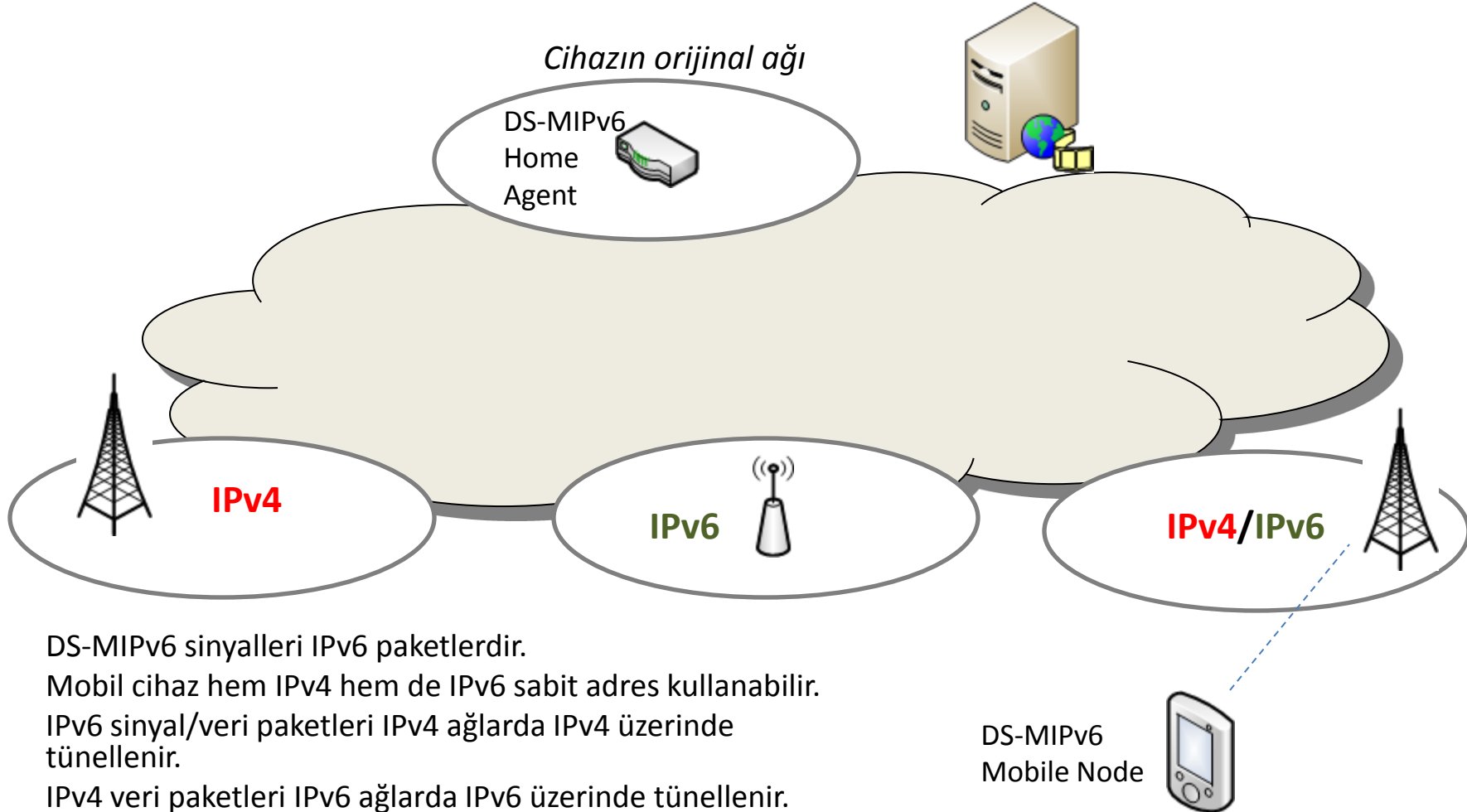

- DS-MIPv6 sinyalleri IPv6 paketlerdir.
- Mobil cihaz hem IPv4 hem de IPv6 sabit adres kullanabilir.
- IPv6 sinyal/veri paketleri IPv4 ağlarda IPv4 üzerinde tünellenir.
- IPv4 veri paketleri IPv6 ağlarda IPv6 üzerinde tünellenir.

# Konum Gizliliği Problemi (??)

- Gizlilik
  - Stateless address autoconfiguration (RFC 2462)

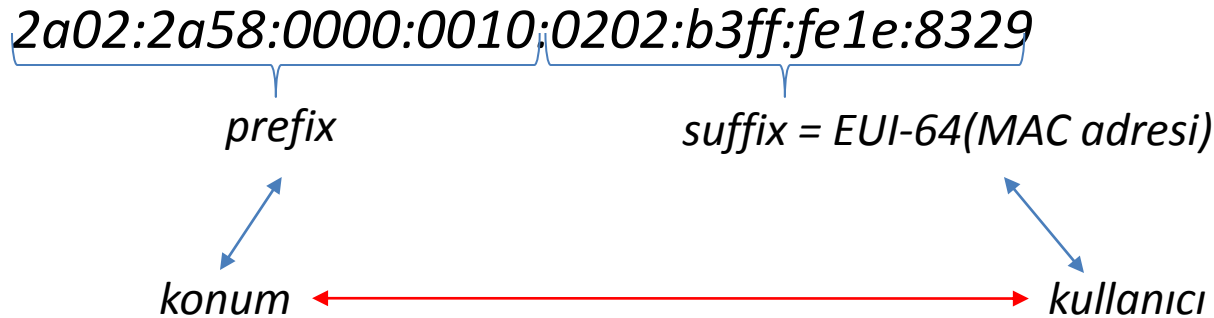

- Risk: Kimlik-konum eşleştirmesi
- Çözüm
  - Her seferinde farklı bir rastgele suffix kullanılması (RFC 3041)

# Bant Geniřlięi Kaybı (??)

IPv4 header  
20+ bytes

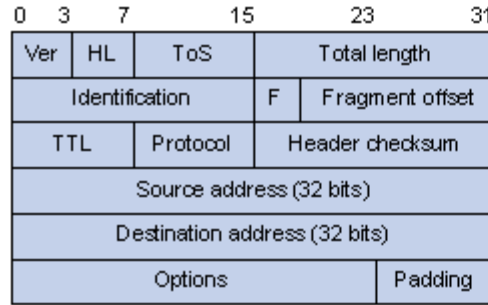

IPv4 header

IPv6 header  
40+ bytes

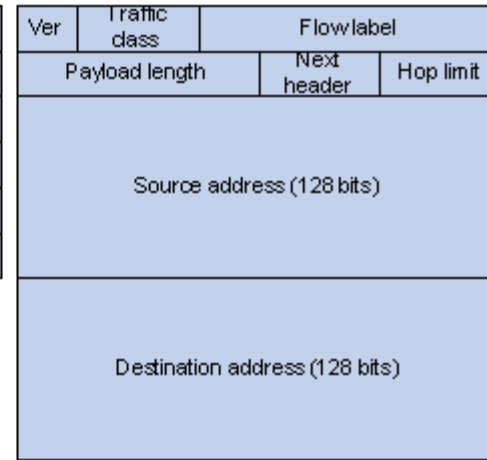

Basic IPv6 header

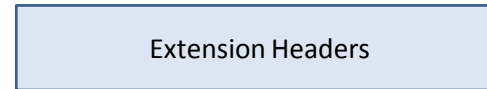

Extension Headers

IPv6	UDP	RTP	Voice
40 byte	12	8	~30 byte

Eriřim aęında uygulanan sıkıřtırma teknięiyle IP bařlıkları 1-2 byte'a kadar indirgenebilir.

Comparison of the IETF header compression standards:

IETF standard	RFC 1144 (VJ, CTCP)	RFC 2507 (IPHC)	RFC 2508 (CRTP)	RFC 3095 (ROHC)
Headers	IPv4/TCP	IPv4 (including options and fragments), IPv6 (including extension headers), AH, Minimal Encapsulation header, Tunnelled IP headers, TCP (including options), UDP, ESP	IPv4, IPv6 (including extension headers), AH, Minimal Encapsulation header, Tunnelled IP headers, UDP, RTP	IPv4 (including options and fragments), IPv6 (including extension headers), AH, Minimal Encapsulation headers, GRE, Tunnelled IP headers, UDP, RTP, ESP
Header compressed to minimum	2 bytes	2 bytes	2 bytes	1 byte

# 3GPP Release 99

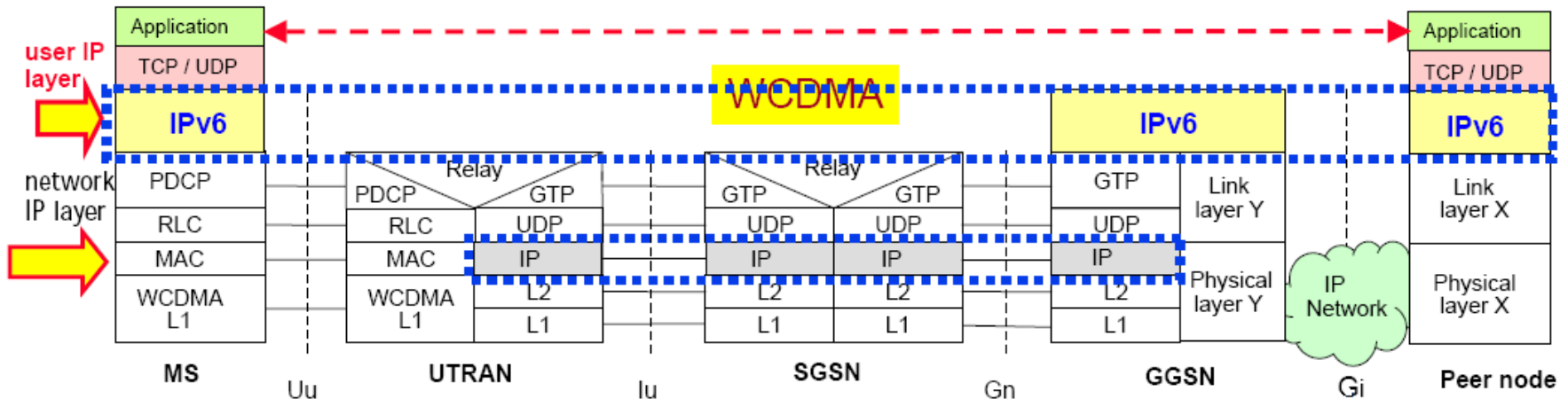
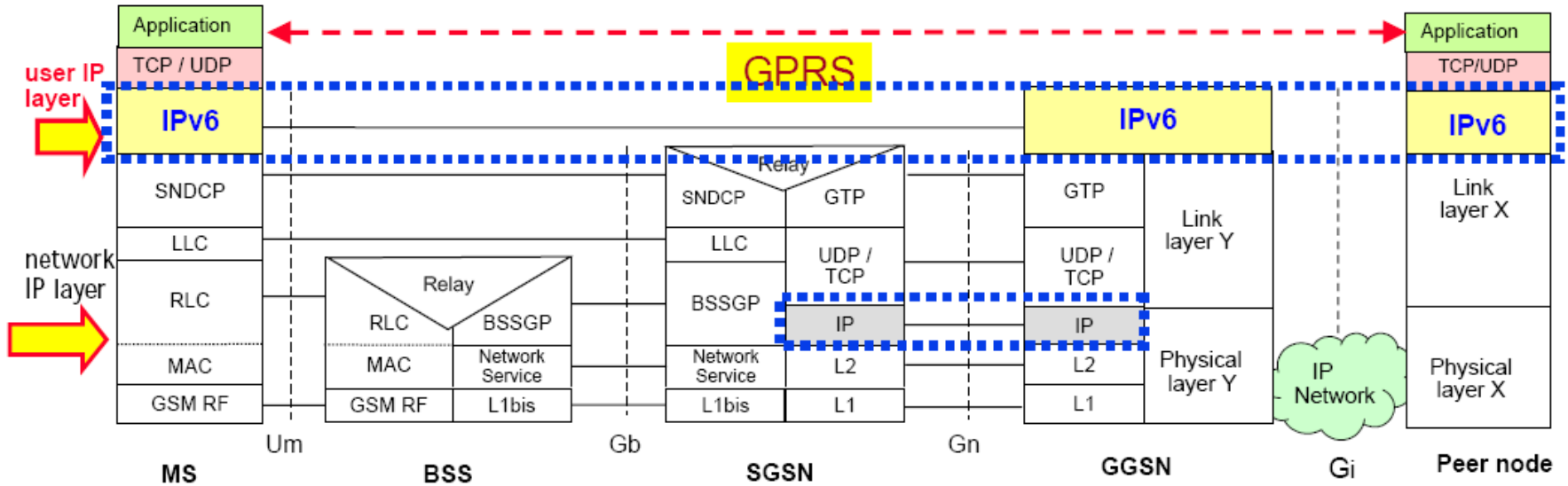

# Dual-Stack Terminal

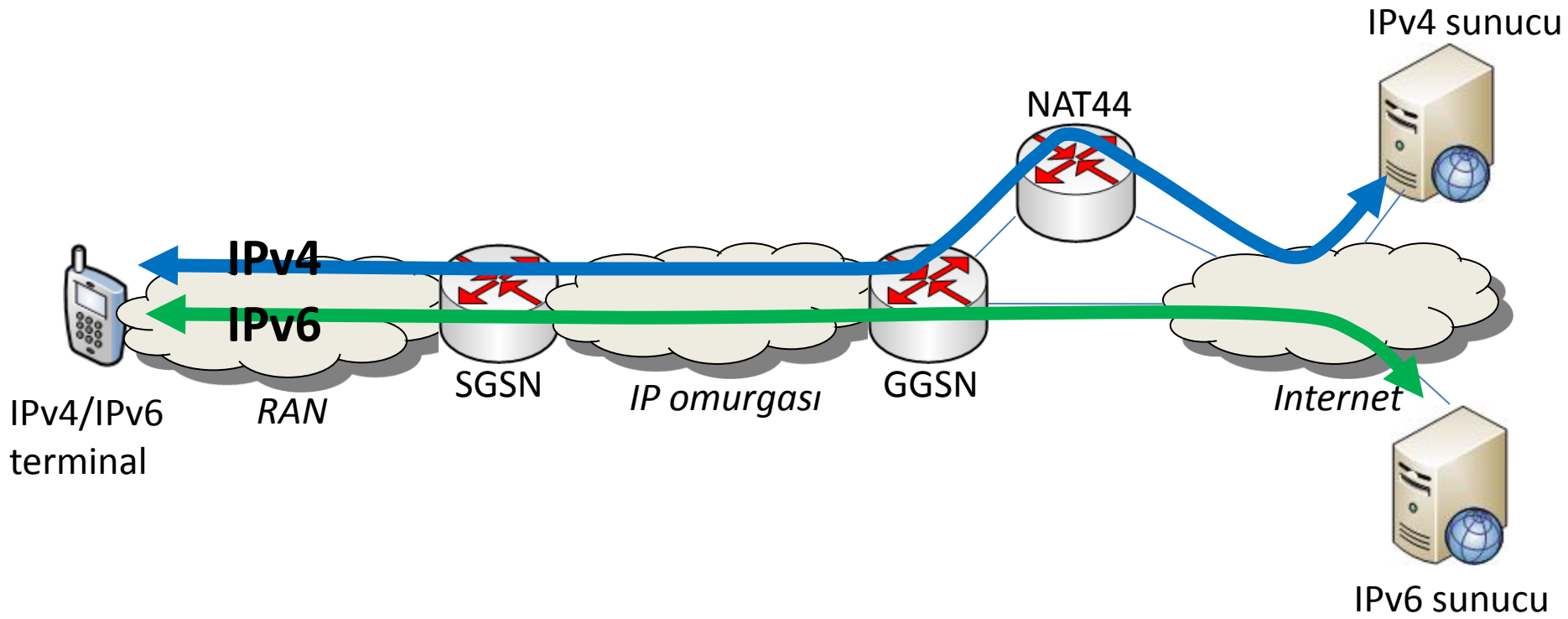

# IPv6 Terminal (NAT64+DNS64)

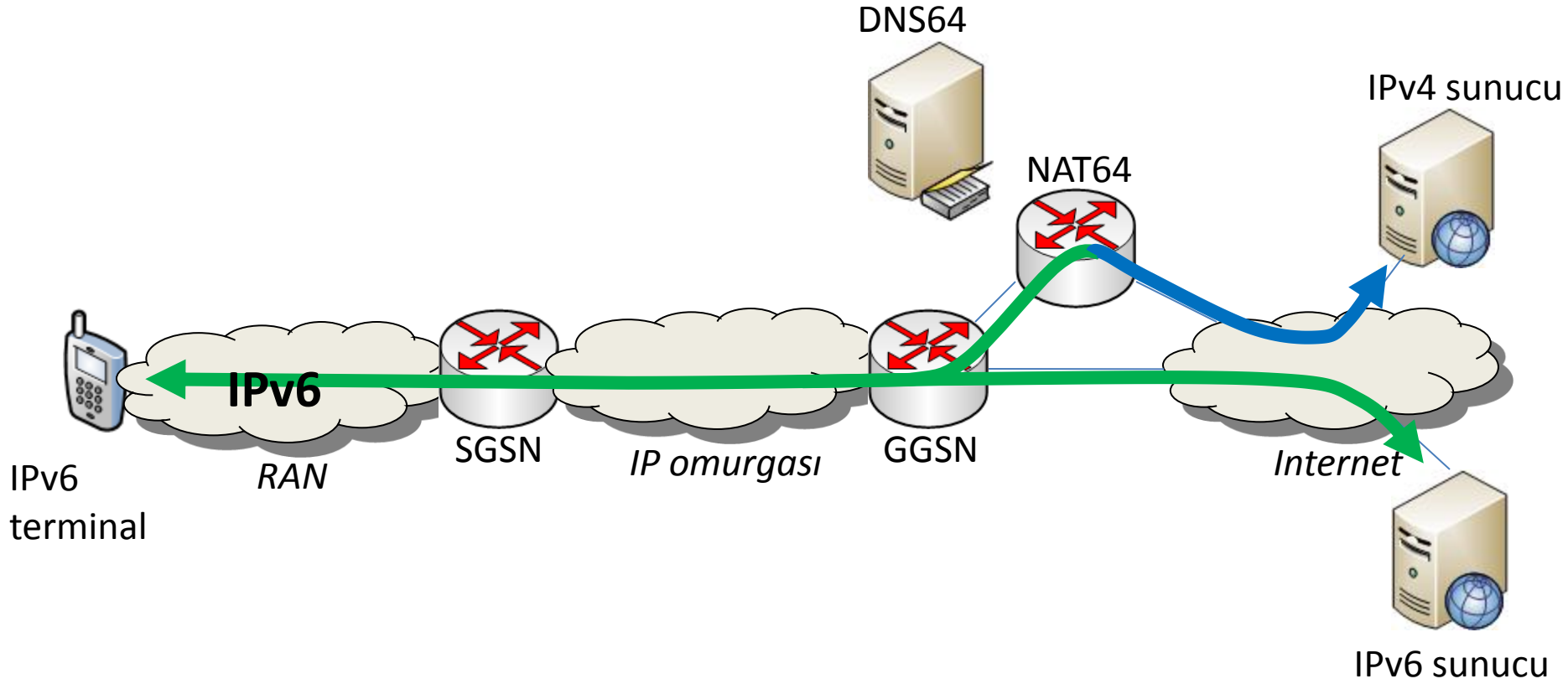

Problem: Web içeriğinde FQDN yerine IPv4 adreslerinin kullanılması.

# WiMAX Release 1

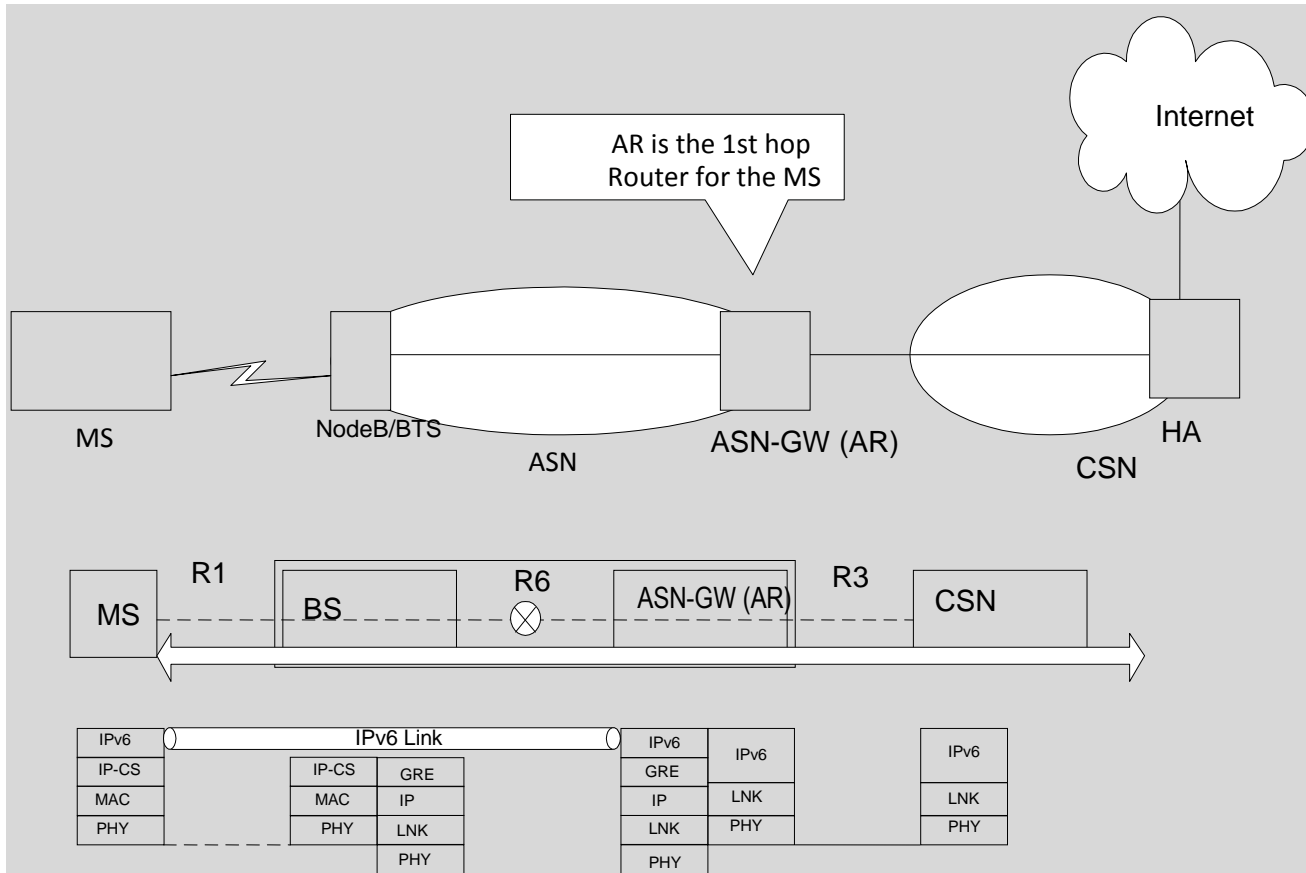

# Bileşenler

- Mobil terminaller
  - Symbian, Android, iOS, Linux, Windows
- Operatörler
  - Pilot uygulama çoğunda var!
  - Ticari uygulama?
    - Telia Sonera, Mobitel, Tasmobil, ... Verizon (LTE)
- Web içeriği
  - Az...
  - Google, Facebook, CNN, Netflix, [ipv6.beijing2008.cn/en](http://ipv6.beijing2008.cn/en)

# 2003

- <http://www.isoc.org/briefings/014/briefing14.pdf>



June 20, 2003

## IPv6: Necessary for Mobile and Wireless Internet

ISOC MEMBER BRIEFING #14

Authors: Alper Yegin, Carl Williams

### 1. Background

Internet architecture is going through an exciting evolution with the emergence of wireless access technologies. This new Internet not only requires a larger IP address space, but also a number of fundamental features to enable wireless networking and mobility. The current state of IPv4-NAT architecture simply does not adequately serve this new Internet especially in terms of security, mobility, extensibility, and dynamic reconfigurability. IPv6 is rapidly emerging as the preferred platform to meet the many needs of the new Internet.

### 2. Technical Issues and Implications

#### Expanded Coverage from ISOC

In-depth articles, papers, links and other resources on a variety of topics are available from the ISOC site at: [www.isoc.org/internet/issues](http://www.isoc.org/internet/issues)

#### Examples in the News

Nordic Wireless Watch  
Wireless Week

#### Relevant IETF RFCs

A detailed list of relevant RFCs and Internet-drafts can be found from the working group

# Çok Bileşenli Geçiş

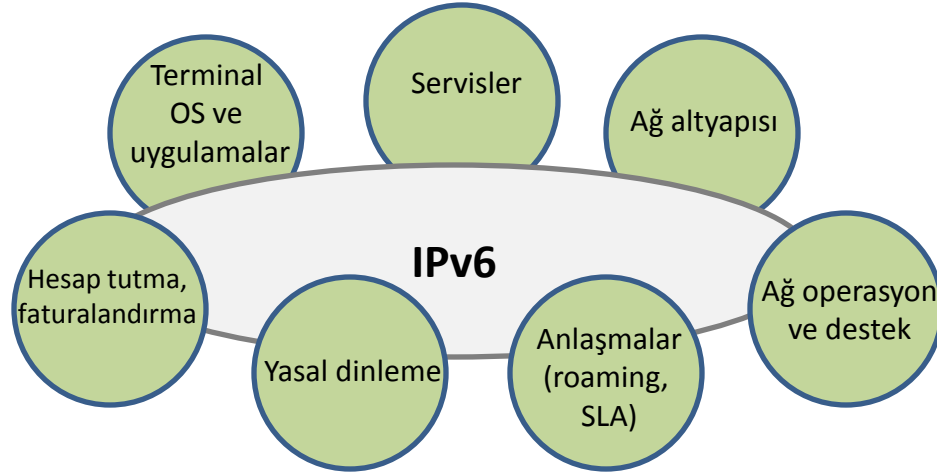

- Bu arada mühendisler sürekli yama geliştirmeye devam ediyor:
  - NAT, NAT444, CGN, STUN, TURN, ICE, RSIP, MIDCOM, IGD, SOCKS, ALG, ...

IPv6'e geiř...  
...IPv6'le bařlangı

# Smart Grid

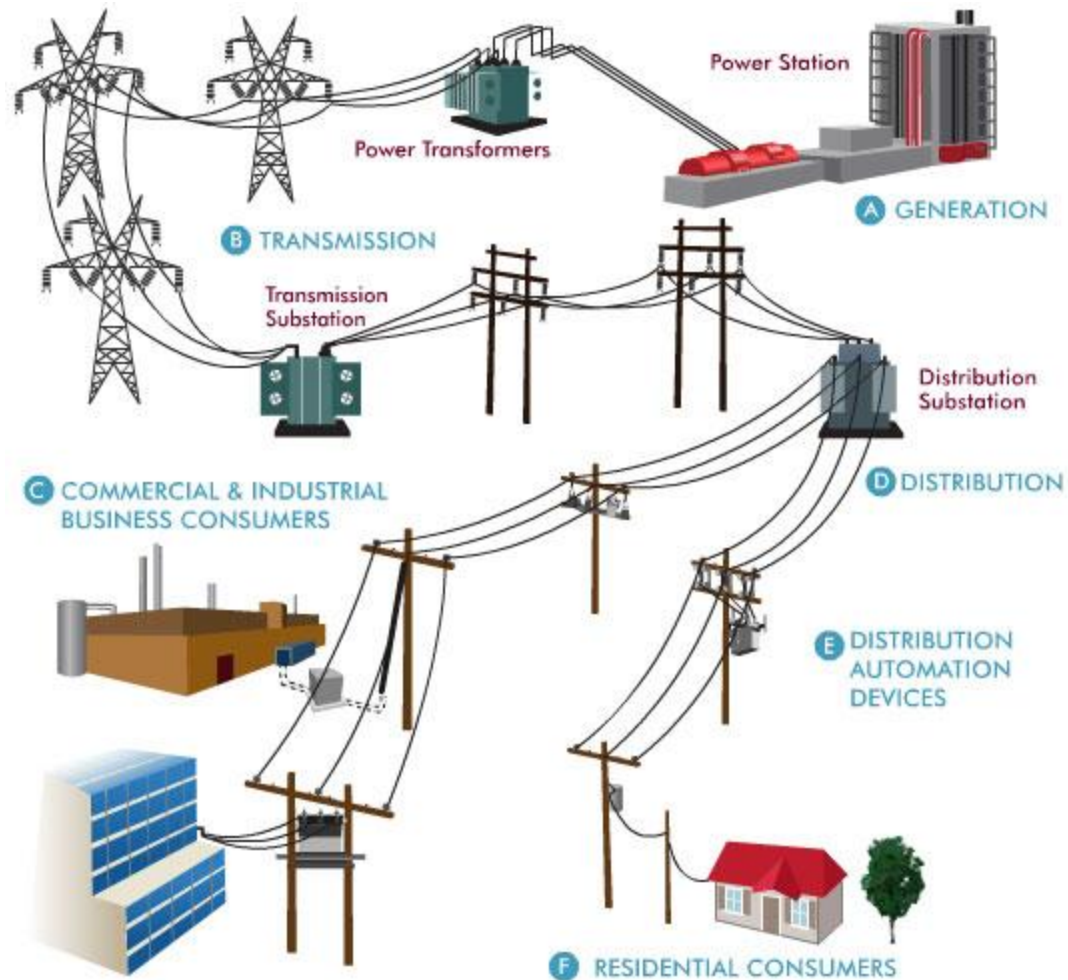

# Home Area Network

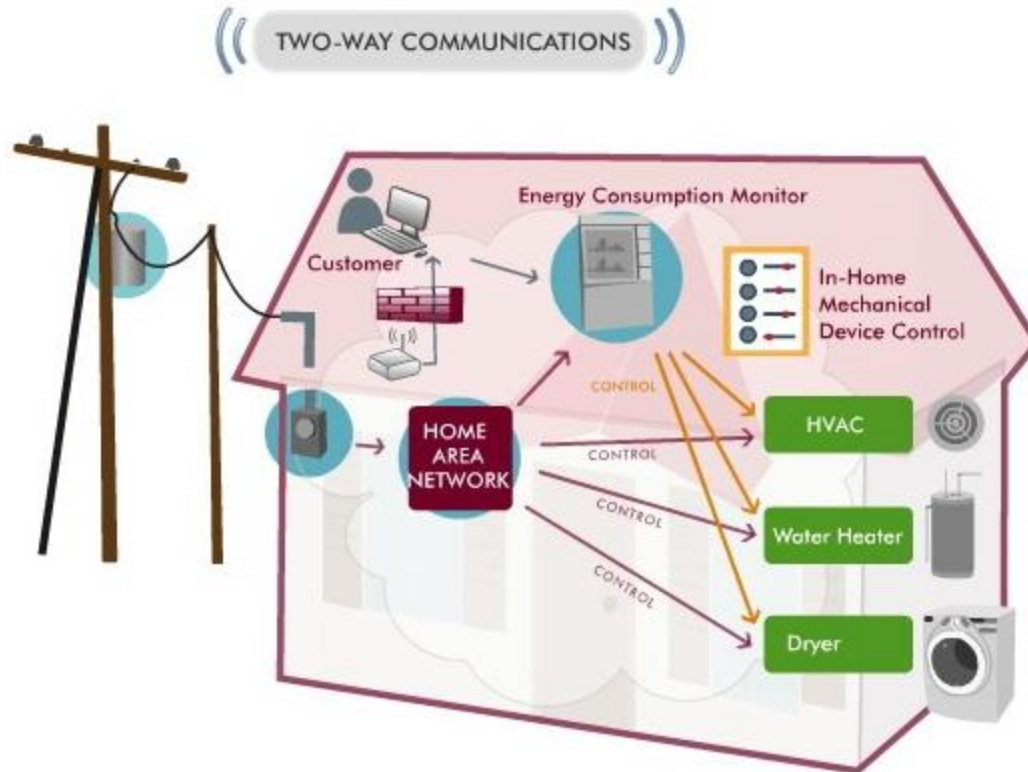

# Zigbee IP

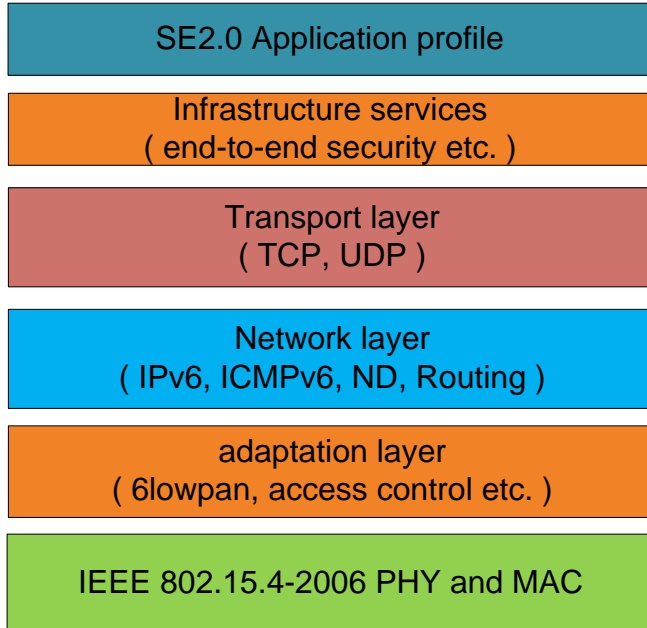
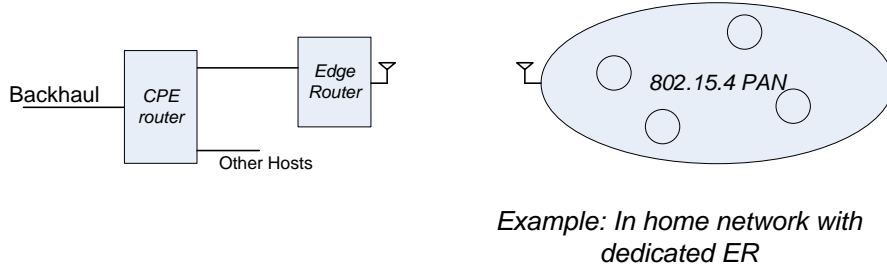

- Sadece IPv6!
  - Yeni sistem
  - Her iki IP versiyonunu barındırmak pratik değil.
    - 32K hafıza, 8bit işlemci
  - Özel amaçlı
    - Üzerinde “genel amaçlı” uygulama çalışmasına, IPv4 Internet’e bağlanmasına gerek yok.

# İlgili Kaynaklar

- CMCC IPv6 Deployment in Cellular Networks Workshop (5-6 Kasım 2009)
  - <http://ipv6ws.arkko.com/>
- IETF-3GPP Workshop on IPv6 in Cellular Networks (1-2 Mart 2010)
  - <http://www.3gpp.org/ftp/workshop/2010-03-01 IPv4-to-IPv6 with-IETF/docs/>
- Google's IPv6 Implementers Conference (10-11 Haziran 2010)
  - <https://sites.google.com/site/ipv6implementors/2010/agenda>

Teşekkürler...